

Modeling Nitrate Dynamics and its Environmental Impact in the Classroom

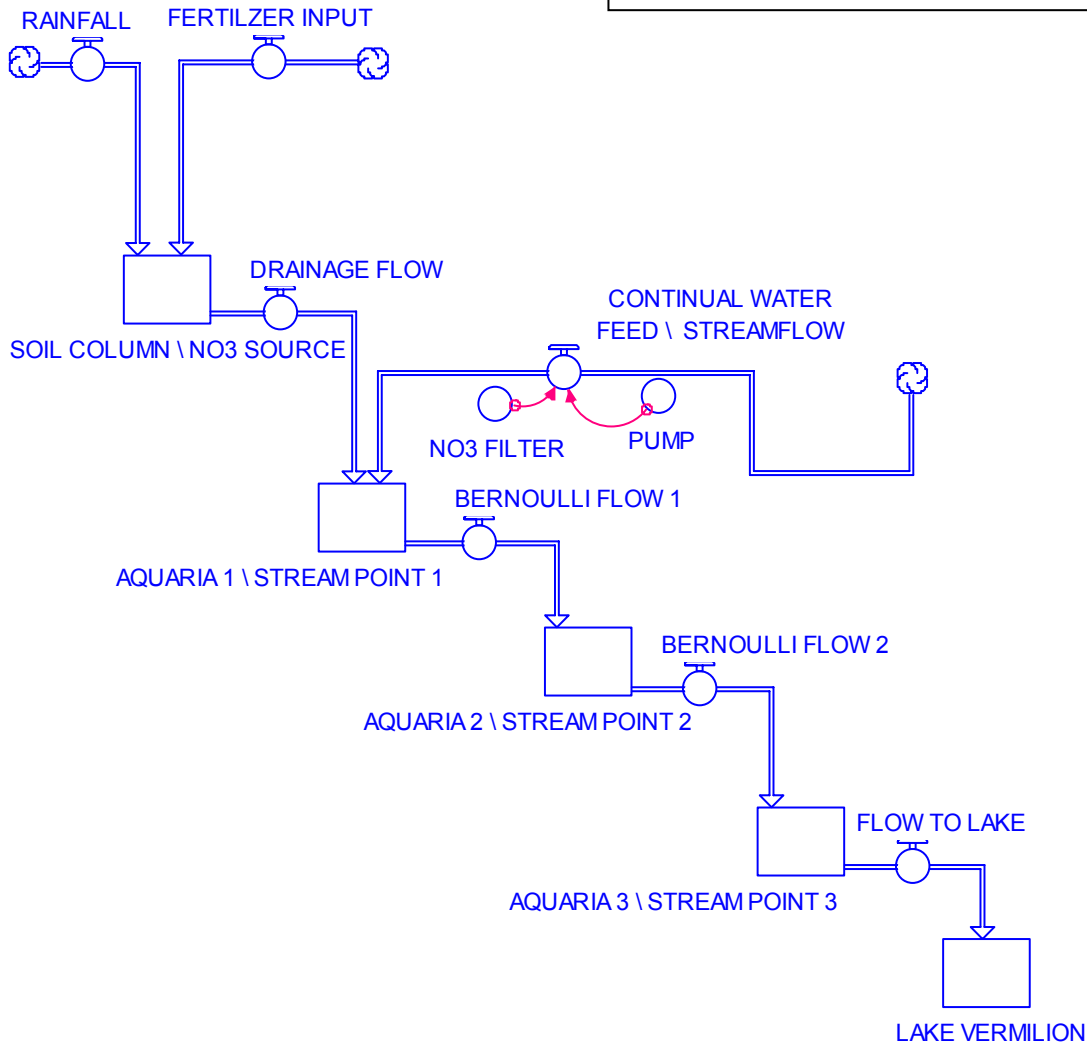

A scheme such as the one modeled above in STELLA could be constructed from the aquaria that are currently in your possession. This would allow an actual physical model of the North Fork of the Vermilion River to be in your classrooms; thereby making it easier to obtain samples, to test hypotheses and, most importantly, to allow you and your students to exchange ideas about creating and conducting scientific experiments. Potentially, we could create two identical sets of systems placing one in the junior-high and one in the high school side of B-H. Each system set would be comprised of an experimental system, which could be dosed with increased amounts of nitrate/ammonium fertilizer or first be planted with a crop such as corn, and an untreated control system. The number of experiments and corresponding results depends entirely on the number of setups that we are able to construct.

Once in place, students could begin to test any number of different hypotheses such as: how do nitrogen concentrations in the stream change in response to changes in rainfall rate; how does having a crop planted in the soil column affect dissolved oxygen in Lake Vermilion; or more fundamental questions such as what is the dependence of dissolved oxygen on temperature and position in the system. Measurement of such factors as dissolved oxygen and nitrate at points both along the stream and within the Lake Vermilion Reservoir (larger tank to receive the water flowing

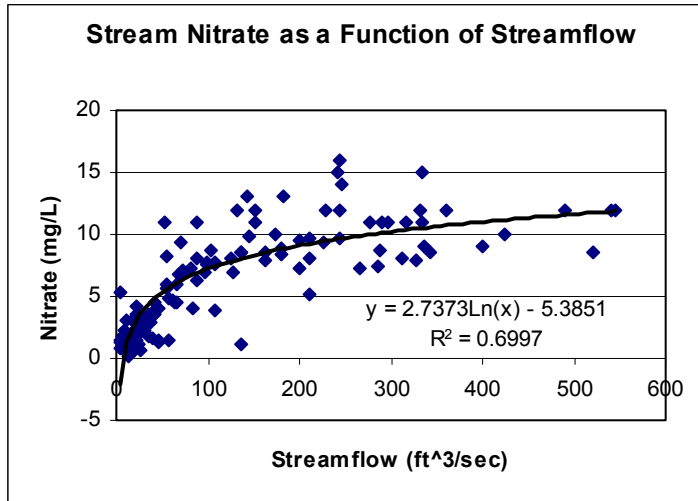

through the aquaria) could be made following established methods. But even better than that, you and the students could actively model the proposed system, test the reliability of the stream model with actual data obtained from the USGS and then project how water quality will change as a result of our agricultural processes using the results from the model.

An example of the type of data available is included in the excel file corresponding to this document. The charts seen on the left were composed from data taken from the USGS sampling station under the bridge at the corner of County Roads 2750 and 1600 in Bismarck; but more importantly, they depict just two of many fundamental relationships that could be discovered in biology, chemistry and physics classes at Bismarck-Henning!

